

Series  
**EPX**

**SIZE 20 REAR REMOVABLE REAR RELEASE CRIMP SOCKET CONTACT ALUMEL  
FOR AWG 20, 22 AND 24 CABLES**

Issue:  
**June 28, 2007**

Page  
**1/1**

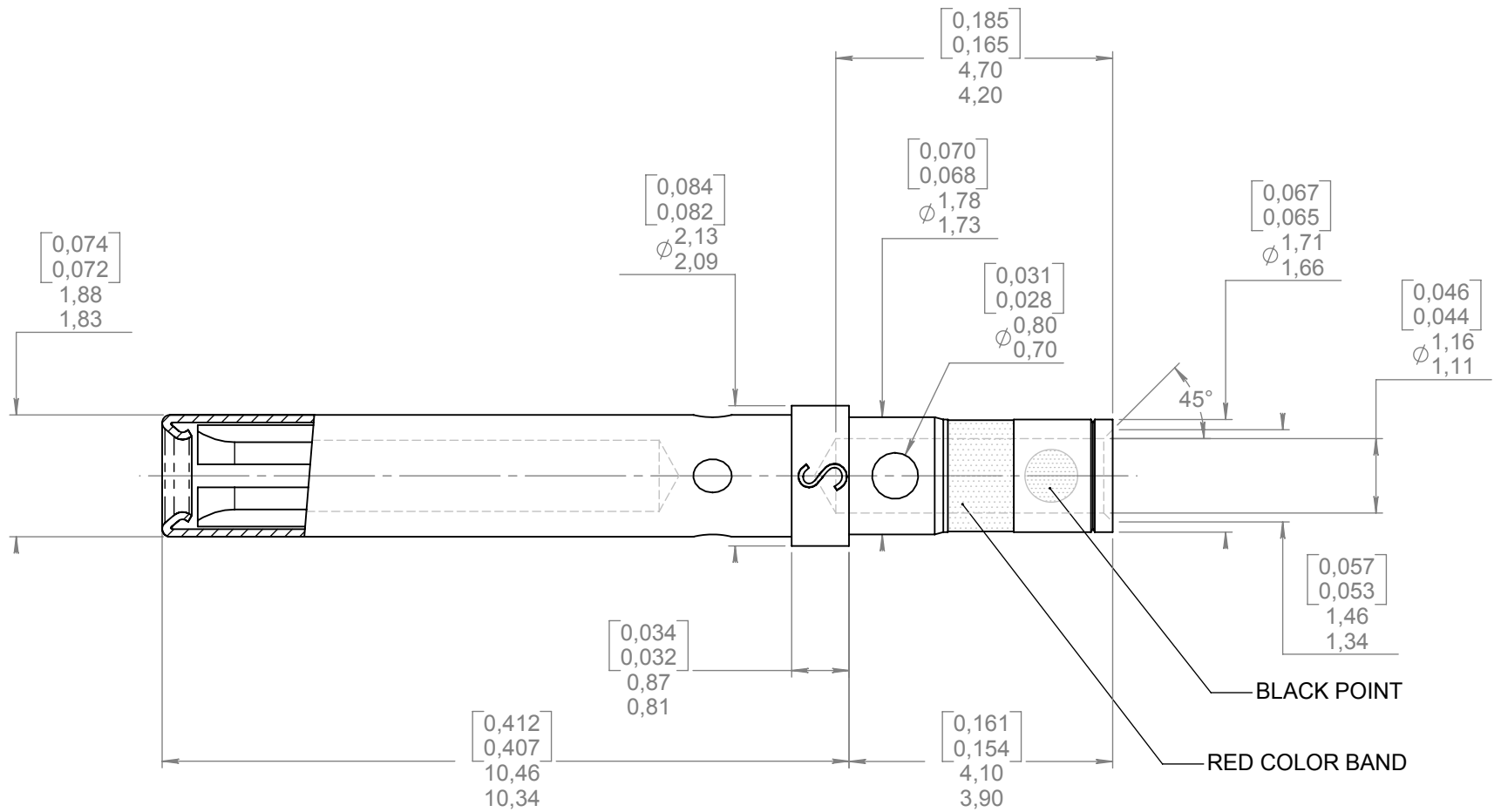

**MATERIAL AND FINISH :**

CONTACT BODY : ALUMEL  
PROTECTION SLEEVE : STAINLESS STEEL PER SAE AMS-5514 , PASSIVATED PER SAE AMS-QQ-P-35

**WIRING INSTRUCTIONS :**

WIRES ACCOMODATED : AWG 20 - 22 and 24  
INSULATION DIAMETER : 1,80 max (.071)  
STRIP LENGTH : 4 (.158)

**TOOLING : (ORDERED SEPARATLY)**

CRIMPING TOOL : M22520/2-01 (RADIALL P/N : 282281)  
SELECTOR POSITION : 7 FOR AWG 20  
6 FOR AWG 22  
5 FOR AWG 24

POSITIONER : M22520/2-08 (RADIALL P/N : 282971)  
INS/EXT TOOL : M81969/1-02 (RADIALL P/N : 282886)  
SPL RADIALL INS. 282 881 / EXT. 282 891

**DIMENSIONS : mm (inch are given for information only)**

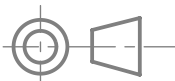

Confidential information not to be disclosed to third parties without Radiall approval. This information is given as an indication. In the continual goal to improve our products, we reserve the right to make any modifications judged necessary.

4112\_9311

<b>CREATION</b>				
<b>PEN:</b>				
<b>NOM:</b> FALETTI				
<b>DATE:</b> OCT 21 1992	June 28, 07	Contact material corrected	LE GLOAHEC	PESSARD
<b>APPR.:</b>	DEC 05 2006	DIMENSION CONVERSION UPDATED	VALGRESY	PESSARD
	<b>Issue</b>	<b>Revisions</b>	<b>Name</b>	<b>Approved</b>