

BEST CONTACTS FOR YOUR SUCCESS



**Telegärtner**

KARL GÄRTNER GMBH

---

NETWORKING COMPONENTS

---

COAXIAL CONNECTORS

---

CABLE ASSEMBLIES

---

PRECISION TURNED PARTS

---

PLASTIC INJECTION MOULD PARTS

---

INDUSTRIAL ELECTRONICS

---

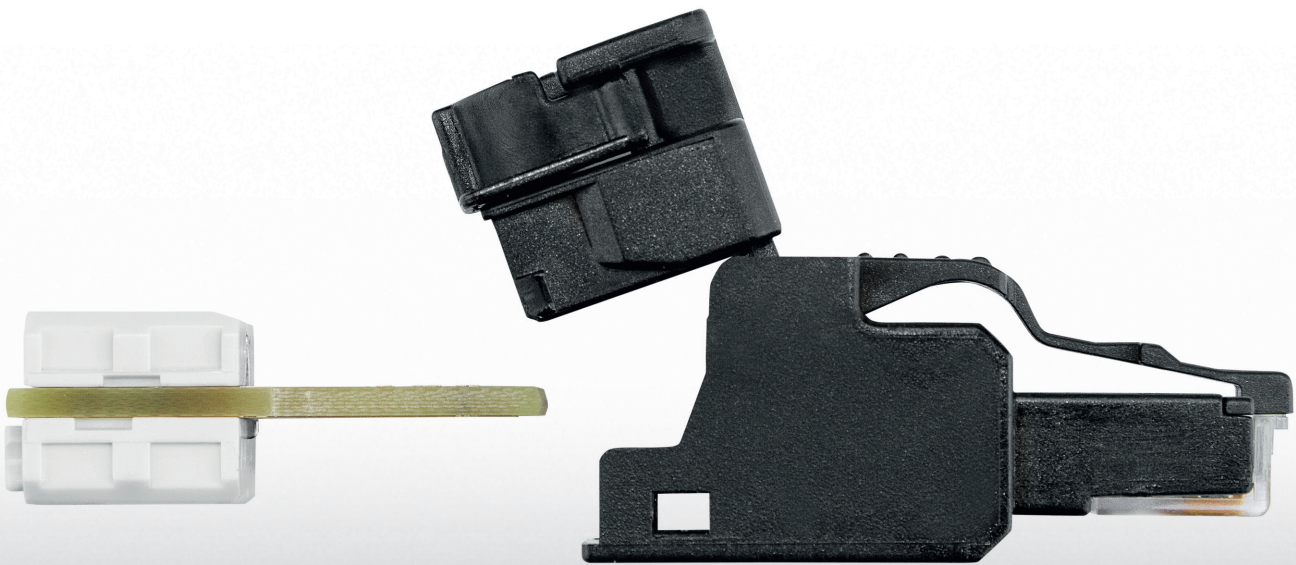

PoE+

500  
MHz

10 GBE

Cat.6A

REAL-TIME  
RE-EMBEDDED

Data Voice

**UFP8 Cat.6A**

Unshielded field assembly RJ45 plug

# UFP8 Cat.6<sub>A</sub> - Unshielded field assembly RJ45 plug

Here's the situation: An existing network needs extending. A cable link needs to be repaired or replaced. A peripheral device needs to be connected quickly. Your customer expects a fast and reliable solution but you don't have a cable assembly ready at hand. Sound familiar?

Now you can keep your cool when faced with such demands – with the new, field assembly UFP8 Cat.6<sub>A</sub> plug developed by Telegärtner.

The UFP8 Cat.6<sub>A</sub> is the RJ45 plug for time-saving and efficient on-site assembly for all networks, from Voice right through to 10 Gigabit Ethernet. It can be assembled on all standard types of cable in just 60 seconds – and no special tools are required.

Whether in the office, in data centers or in home networks – the UFP8 Cat.6<sub>A</sub> offers unprecedented flexibility and saves time and money on installation, repairs and maintenance.

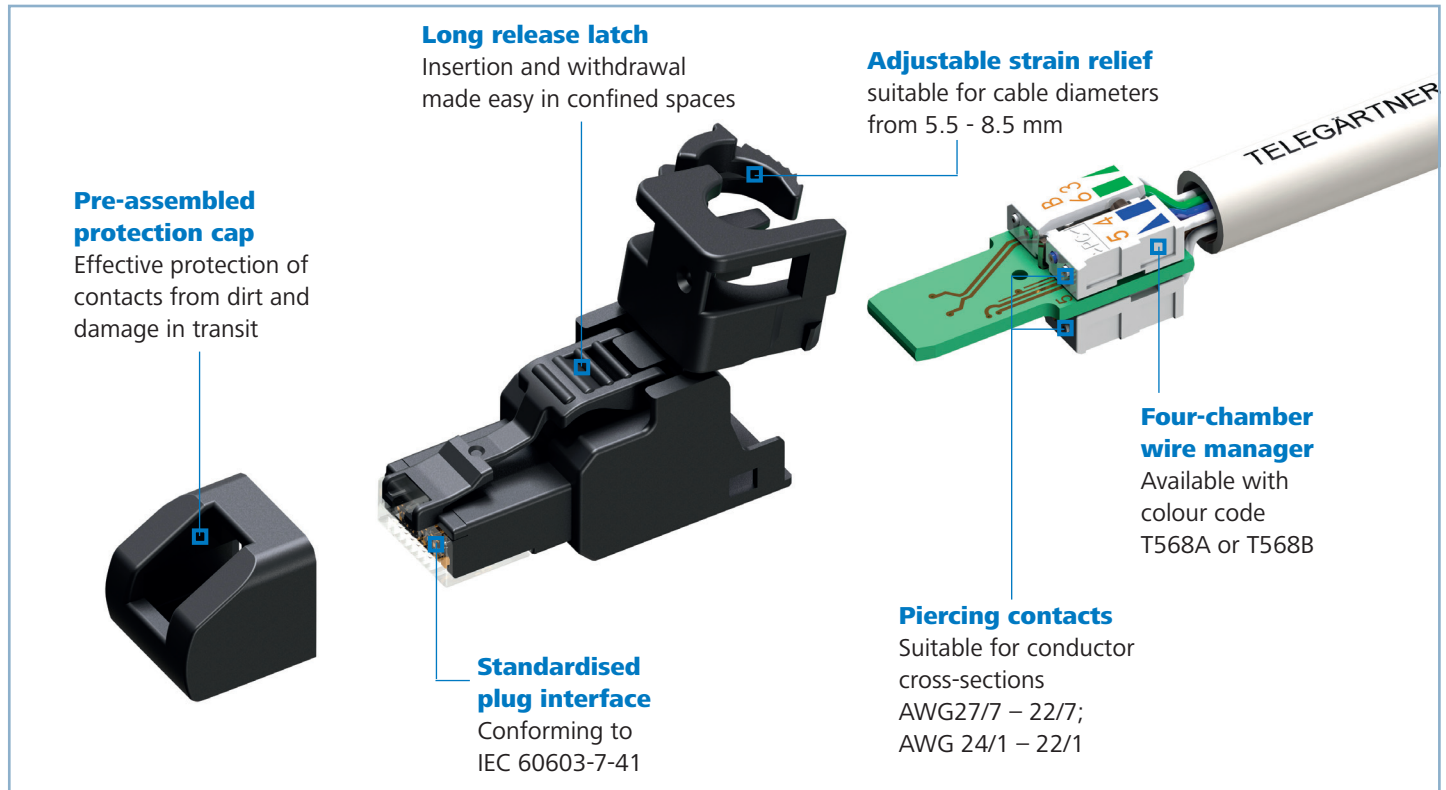

## Performance Characteristics

- Category 6<sub>A</sub>: ISO/IEC 11801:2010; Category 6A: ANSI/TIA/EIA-568-C.2
- plug: IEC 60603-7-41
- life: ≥ 750 mating cycles
- contact finish material: Ni1.2Au0.8
- housing material: PC UL94-V0 black
- Cu conductor diameter:  
solid 0.51 – 0.64 mm (AWG 24/1 – 22/1) or  
stranded 0.46 – 0.76 mm (AWG 27/7 – 22/7)
- core diameter: 0.85 – 1.1 mm
- outer diameter of cable: 5.5 – 8.5 mm
- reusable piercing contacts: ≤ 4 cycles
- temperature range: -40°C to 70°C
- High Power over Ethernet plus (PoE+) in accordance with IEEE 802.3at
- UL listed

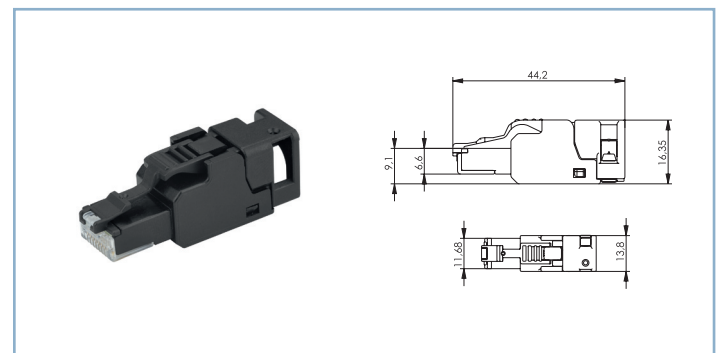

Order no.	Description	Remarks
J00026A3000	UFP8 T568A Cat.6 <sub>A</sub>	1 pc. in PE-bag, 10 bags in carton
J00026A3001	UFP8 T568B Cat.6 <sub>A</sub>	1 pc. in PE-bag, 10 bags in carton
J00026A3110	UFP8 T568A Cat.6 <sub>A</sub>	blister package (10 pcs.)
J00026A3111	UFP8 T568B Cat.6 <sub>A</sub>	blister package (10 pcs.)

## Assembly steps

