

**UNCONTROLLED DOCUMENT  
WILL NOT BE UPDATED**

REVISIONS				
REV. SYM.	E.C.O. NUMBER	DESCRIPTION	BY DATE	APP'D DATE
10		REVISED SET INFO	ENF 4-3-14	RRR 4-3-14

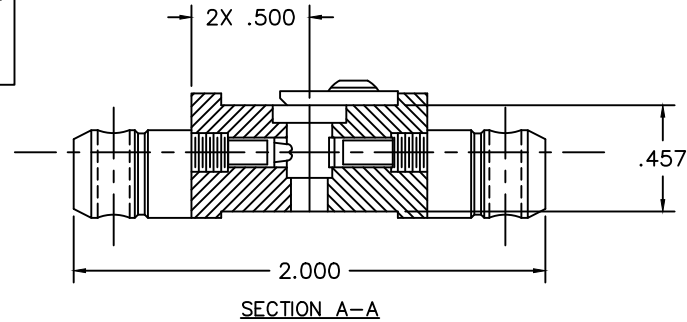

**TO SET DIE:**

1. UNLOCK & BACK INDENTERS SLIGHTLY OUT OF THE CAVITY
2. INSERT Y631-SG INTO HOLE FROM BACK SIDE OF DIE AS FAR AS IT WILL GO WITH THE SLOT ALIGNED WITH THE FLAT RECTANGULAR INDENTER
3. ADJUST THE FLAT RECTANGULAR INDENTER UNTIL IT TOUCHES THE SET GAGE (PAY CLOSE ATTENTION TO LINE IT UP IN THE SLOT & DO NOT OVER TIGHTEN)
4. ADJUST POINTED INDENTER UNTIL IT TOUCHES THE SET GAGE (DO NOT OVER TIGHTEN)
5. REMOVE Y631-SG
6. VERIFY INDENTER GAGE WITH G668 AND ADJUST POINTED INDENTER IF NEEDED

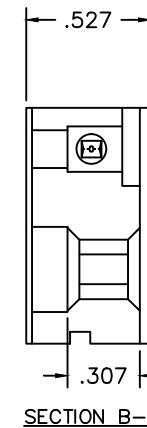
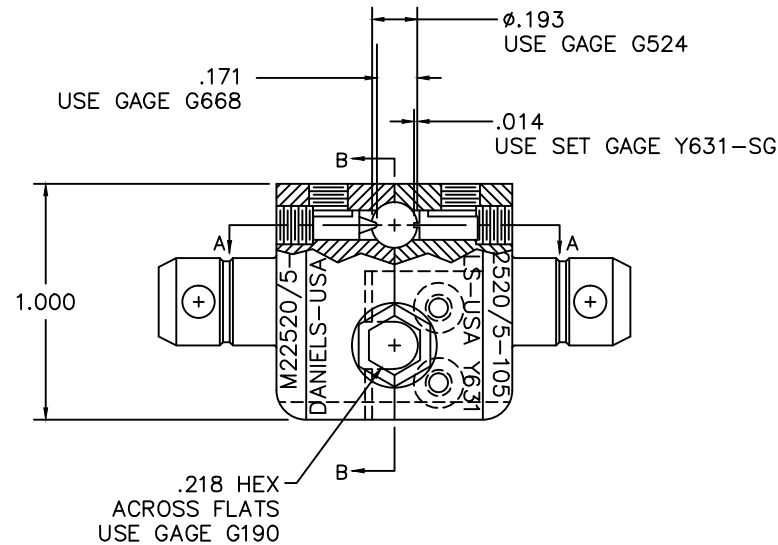

1. TROMPETER CD5-4.

NOTES:

<p><b>RESTRICTED &amp; CONFIDENTIAL</b></p> <p>CONFIDENTIAL PROPERTY OF DANIELS MANUFACTURING CORP. NOT TO BE DISCLOSED TO OTHERS, REPRODUCED OR USED FOR ANY OTHER PURPOSE, EXCEPT AS AUTHORIZED IN WRITING BY DANIELS MANUFACTURING. MUST BE RETURNED TO DANIELS MANUFACTURING CORP. ON COMPLETION OF ORDER OR OTHER PURPOSE FOR WHICH LEV'T.</p>	MATERIAL	ITEM	PART NO.	QTY.	DESCRIPTION/REMARKS
	HEAT TREAT	DRN. B. KILPATRICK	DATE 4-17-98		 <p>DANIELS MANUFACTURING CORP. ORLANDO, FLORIDA CAGE 11851</p>
	FINISH	CHK'D. DAD	DATE 4-98		
	DO NOT SCALE DRAWING		APP'D.	DATE	TITLE
		NOTE:	<p>THIS DRAWING IS AN OUTLINE DRAWING OF THE RESPECTIVE DMC PART NUMBER INDICATED. ACTUAL DMC PART NUMBER IS DRAWING NUMBER WITHOUT THE "-ENV" SUFFIX.</p>		<p>WHERE USED:</p> <p>SIZE B SCALE 2X CAD P/N Y631-ENV SHEET 1 OF 1</p>
				POSTING	<p>DWG. NO. Y631-ENV REV. 10</p>