

# WA23 HEAVY DUTY PNEUMATIC CRIMP TOOL (M22520/23-01)

SEE PAGE 3 FOR IMPORTANT INFORMATION CONCERNING LIMITED WARRANTY, AND LIMITATION OF LIABILITY.

## HOW TO USE THE DANIELS WA23 PNEUMATIC CRIMP TOOL AND RELATED DIE ASSEMBLIES/LOCATORS

### GENERAL INFORMATION

1. The DMC WA23 is a heavy duty pneumatic crimp tool, designed to produce four-indent crimps on contacts, sizes 8 thru 4/0 AWG. Various sizes and types of contacts are accommodated by changing indenter die assemblies and locators.
2. This precision crimp tool is designed to operate on a supply of regulated and filtered air or inert gas within a pressure range of 90–120 psi.
3. This tool is supplied with a standard pneumatic connector for most applications. The air inlet is tapped to accommodate 1/4 NPT fittings.

### BASIC OPERATION

Read carefully all caution labels before installing any die assembly and locator.

**CAUTION:** DISCONNECT AIR SUPPLY BEFORE INSTALLING OR REMOVING DIES AND LOCATORS.

### INSTALLATION OF LOCATOR

1. Unscrew the retainer ring and remove die assembly, if installed. Insert the locator in the center hole, FIG. 1.
2. Verify that the flange on the locator is seated in the counterbore, and the notch on the flange, FIG. 2, is aligned with the locator alignment pin, FIG. 3.

### INSTALLATION OF THE DIE ASSEMBLY

1. Place the indenter die assembly, as shown in Fig. 1, onto the tool frame. The die assembly alignment pin, FIG. 3, must fit into the corresponding hole in the die assembly. Place the retainer ring over the die assembly Fig. 1, and tighten to hold the assembly flush with the tool body.
2. Connect the air supply. Adjust the air pressure to 90–120 psi. Without contact or wire in place, press the trigger to activate the tool.
3. Confirm that the indenters move freely.

### GAGING THE DIE ASSEMBLY

1. The GO and NO-GO dimensions are marked on the face of each die assembly. The appropriate gage pins are available from DMC.
2. To check the die closure of the mounted die assembly, press the trigger and hold it in place.
3. Insert the GO gage pin between the closed indenters. The gage pin must pass between the indenter tips.
4. With the indenters still in the closed position, try to insert the NO-GO gage pin between the tips. The NO-GO gage must not pass through the opening.

**CAUTION:** DO NOT CRIMP GAGE PIN. THIS WILL DAMAGE THE TOOL AND VOID WARRANTY.

### CRIMPING THE CONTACT

1. Assemble the contact and the wire to be crimped, and insert into the tool. Push the contact in until it bottoms on the locator. Press the trigger to cycle the tool, and release.
2. Remove the crimped contact assembly. Visually inspect the crimp to verify crimp quality and location.

**WARNING:** DURING THE CRIMP CYCLE KEEP FINGERS AWAY FROM THE DIE OPENING AREA.

### RESETTING THE TOOL

1. The WA23 tool is equipped with an internal reset switch. If, for any reason, the tool fails to cycle fully, remove the three screws that hold the handle cover, and press the black button on the left side.
2. When the tool is reset, replace the cover.

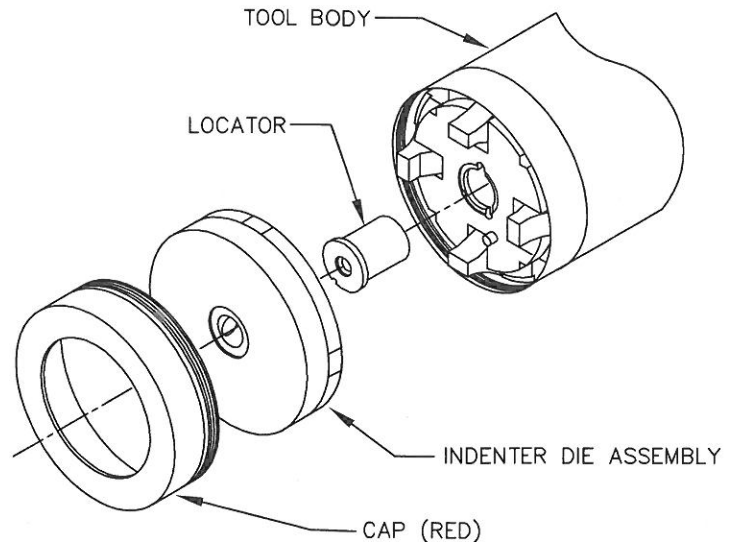

FIG. 1

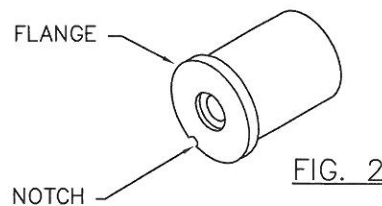

FIG. 2

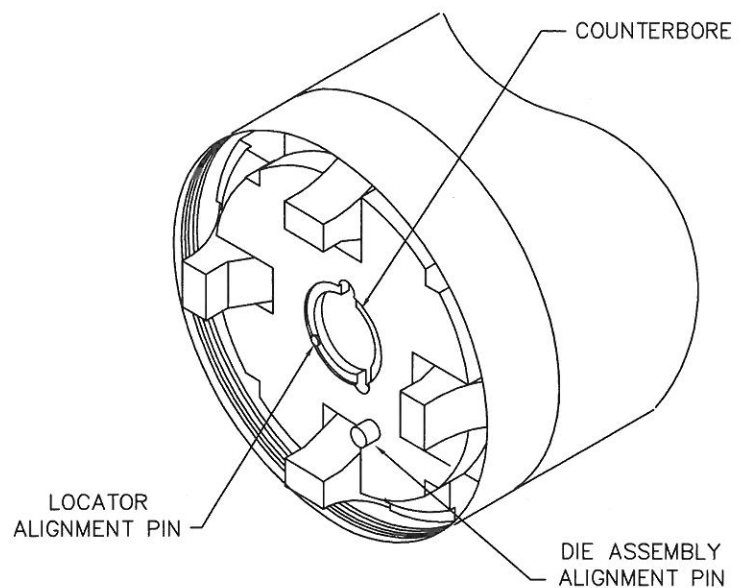

FIG. 3

SAFETY SIGNAGE

1. Safety signs are placed on the WA23 power crimp tool to make you aware that this tool could seriously injure or maim you if care is not used while operating it.
2. These signs are intended as a constant reminder of the potential risks involved. These signs should never be removed and should be replaced as needed.
3. Signs alone will not prevent accidents from occurring. Operators must be properly trained in the use of the equipment and be aware of the risks involved. While using the tool, it is important to be alert and avoid distractions.



OPERATING  
PRESSURE  
90-120 P.S.I.



RELOCATING THE TOOL

1. The DMC WA23 tool is designed to be able to be moved from location to location when necessary. The WA23 is not intended to be a hand tool and carried constantly.
2. To move the tool, make sure that the indenter area is free of contacts. Disconnect the air supply from the tool. Lift the tool using the lifting handle provided.
3. The WA23 is 18.74lb (8.5Kg) and is easily lifted by one person using the lifting handle provided.

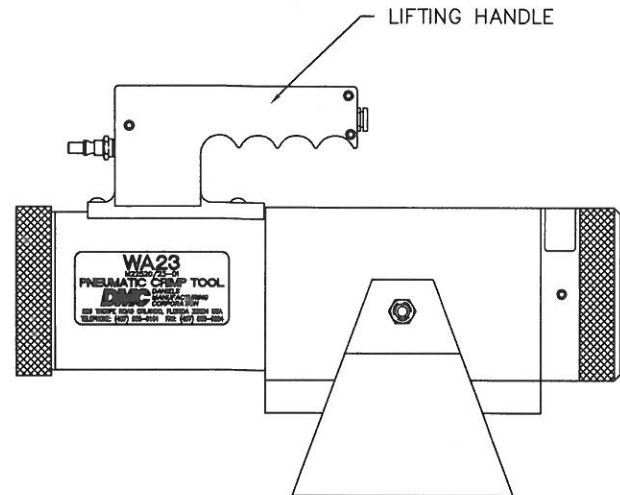

MIL-C-22520 TOOL, DIE ASSEMBLY, AND LOCATOR LIST

MILITARY PART NUMBER	DESCRIPTION	DMC PART NUMBER	CONTACT SIZE	"GO" DIM.	"NO-GO" DIM.	GAGE P/N
M22520/23-01	CRIMP TOOL	WA23				
M22520/23-02	DIE ASSEMBLY 8	WA23-2	8	.130	.136	G693
M22520/23-03	DIE ASSEMBLY 6	WA23-3	6	.171	.178	G694
M22520/23-04	DIE ASSEMBLY 4	WA23-4	4	.195	.202	G695
M22520/23-05	DIE ASSEMBLY 1/0	WA23-5	1/0	.325	.332	G696
M22520/23-06	DIE ASSEMBLY 2/0	WA23-6	2/0	.351	.358	G697
M22520/23-07	DIE ASSEMBLY 4/0	WA23-7	4/0	.425	.432	G698
M22520/23-09	LOCATOR 8	WA23-9	8			
M22520/23-10	LOCATOR 6, 6N, 6G	WA23-10	6, 6N, 6G			
M22520/23-11	LOCATOR 4	WA23-11	4			
M22520/23-12	LOCATOR 4, 4N, 4G	WA23-12	4, 4N, 4G			
M22520/23-13	LOCATOR 1/0	WA23-13	1/0			
M22520/23-14	LOCATOR 1/0, 1/0N	WA23-14	1/0, 1/0N			
M22520/23-15	LOCATOR 2/0, 2/0N	WA23-15	2/0, 2/0N			
M22520/23-16	LOCATOR 4/0, 4/0N	WA23-16	4/0, 4/0N			

### CARE OF TOOL

It is a good practice to keep indenter tips free of residual color band deposits and other debris. A small wire brush may be used for this purpose.

We strongly recommend that you:

1. DO NOT immerse tools in cleaning solution.
2. DO NOT spray oil into tool to lubricate.
3. DO NOT attempt to disassemble tool or make repairs.

This is a precision crimp tool and should be handled as such.

DMC offers complete refurbishing and recalibration services.

DMC specially engineers and manufactures complete tool kits to satisfy individual customer requirements, such as total aircraft support, general shop maintenance or production, on board ship and vehicle service, etc.

#### LIMITATION OF LIABILITY

DANIELS MANUFACTURING CORPORATION IS NOT LIABLE FOR CONSEQUENTIAL OR SPECIAL DAMAGES OF ANY NATURE OR KIND RESULTING FROM THE USE, OR MISUSE, OF ANY OF ITS PRODUCTS. OWNERS AND USERS OF DMC PRODUCTS ASSUME FULL RESPONSIBILITY FOR INSTRUCTING THEIR EMPLOYEES IN THE PROPER AND SAFE USE OF SUCH PRODUCTS.

#### LIMITED WARRANTY

DMC (Daniels Manufacturing Corporation) warrants each new product sold by it to be free from defects in material and workmanship under normal use and service. DMC's obligation under this warranty is limited to the free correction or, at DMC's option, the refund of the purchase price of any such product which proves defective in normal service within ninety (90) days after delivery to the first user, provided that the product is returned to DMC with all transportation charges prepaid and which shall appear to DMC's satisfaction, after DMC's inspection, to have been defective in material or workmanship, it being understood that DMC products are not consumer products. This warranty shall not cover any damage to any product which, in the opinion of DMC, was caused by normal wear, misuse, improper operation, tampering, neglect or accident. This warranty is in lieu of all other warranties express or implied. No warranty, express or implied, is made or authorized to be made or assumed with respect to products of Daniels Manufacturing Corporation other than those herein set forth.