



COAXIAL HIGH IP3

Low Noise Amplifier

ZHL-3010+

50Ω Medium High Power 50 to 1000 MHz

FEATURES

- Wideband, 50 to 1000 MHz
- Low Noise, 5.5 dB typ.
- High IP3, +46 dBm typ.
- Very High IP2, +68 - +83 dBm typ.
- Protected by US Patent 6,943,629



Generic photo used for illustration purposes only

APPLICATIONS

- VHF/UHF
- Cellular
- Test Equipment
- Instrumentation
- Laboratory

Model No.	ZHL-3010+
Case Style	S32
Connectors	SMA

+RoHS Compliant

The +Suffix identifies RoHS Compliance. See our website for methodologies and qualifications

ELECTRICAL SPECIFICATIONS

Parameter	Frequency (MHz)	Min.	Typ.	Max.	Units
Frequency Range		50		1000	MHz
Noise Figure	50 - 1000		5.5		dB
Gain	50 - 1000	30			dB
Gain Flatness	50 - 1000			±1.0	dB
Output Power at 1 dB compression	50 - 1000	+26		-3	dBm
Output third order intercept point	50 - 1000		+46		dBm
Input VSWR	50 - 1000			2.5	:1
Output VSWR	50 - 1000			2.0	:1
DC Supply Voltage			+12		V
Supply Current				1.0	A

Open load is not recommended, potentially can cause damage. With no load derate max input power by 20 dB

ABSOLUTE MAXIMUM RATINGS

Parameter	Ratings
Operating Temperature	-20°C to +65°C
Storage Temperature	-55°C to +100°C
DC Voltage	+13V Max.
RF Input Power (no damage)	-3 dBm

Permanent damage may occur if any of these limits are exceeded.

REV. D
ECO-017949
ZHL-3010+
MCL NY
230524





COAXIAL HIGH IP3

Low Noise Amplifier

ZHL-3010+

50Ω Medium High Power 50 to 1000 MHz

OUTLINE DRAWING

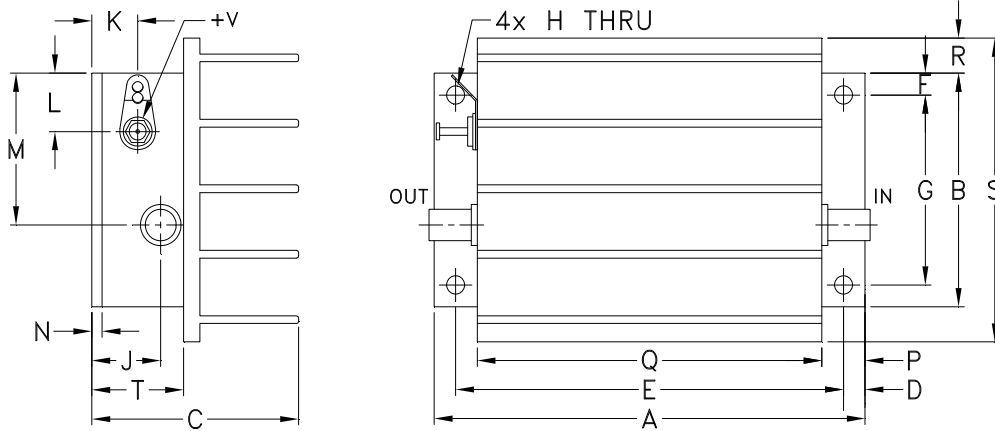

MOUNTING INFORMATION FOR MODELS WITHOUT HEATSINK

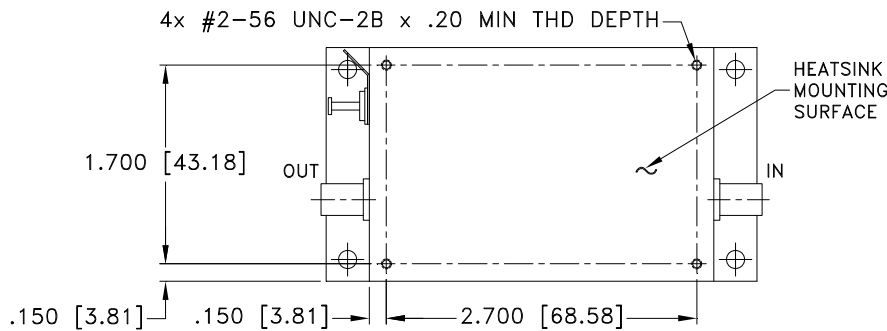

OUTLINE DIMENSIONS (Inch/mm)

A	B	C	D	E	F	G	H	J	K	L	M	N	P	Q	R	S	T	wt	
3.75	2.00	1.80	.19	3.375	.19	1.625	.144	.50	.40	.50	1.30	.10	.38	3.00	.30	2.60	.80	grams	
95.25	50.80	45.72	4.83	85.73	4.83	41.28	3.66	12.70	10.16	12.70	33.02	2.54	9.65	76.20	7.62	66.04	20.32	220.0	
																		wt. w/o heat sink	150



COAXIAL HIGH IP3

Low Noise Amplifier

ZHL-3010+

50Ω Medium High Power 50 to 1000 MHz

TYPICAL PERFORMANCE DATA/CURVES

FREQUENCY (MHz)	GAIN (dB)	DIRECTIVITY (dB)	VSWR (:1)		NOISE FIGURE (dB)	POUT at 1 dB COMPR. (dBm)
	12V	12V	IN	OUT	12V	12V
50.00	36.37	16.10	1.78	1.28	5.14	29.62
155.60	36.23	15.10	2.12	1.77	5.19	30.12
261.10	36.00	15.80	2.19	1.81	5.40	30.67
366.70	36.09	16.50	2.04	1.44	5.44	31.55
472.20	36.21	16.40	1.94	1.07	5.46	30.87
577.80	36.00	15.30	1.91	1.15	5.40	30.76
683.30	35.30	18.20	1.74	1.18	5.30	30.08
788.90	35.60	18.60	1.88	1.01	5.24	30.18
894.40	35.48	17.40	2.08	1.27	5.33	29.93
1000.00	35.29	20.20	2.04	1.56	5.43	28.74

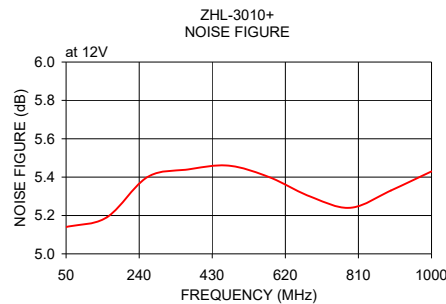
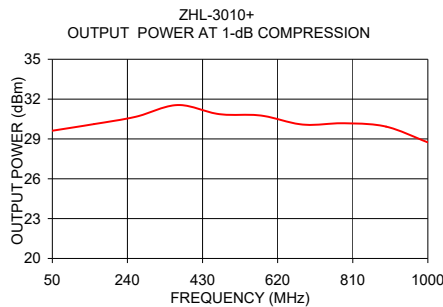
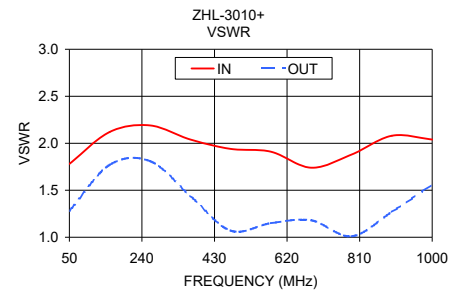
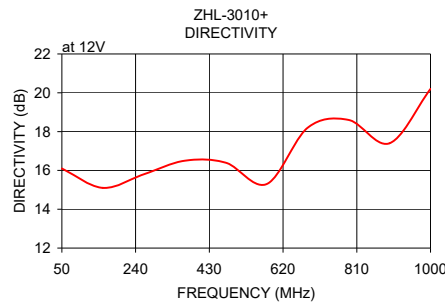
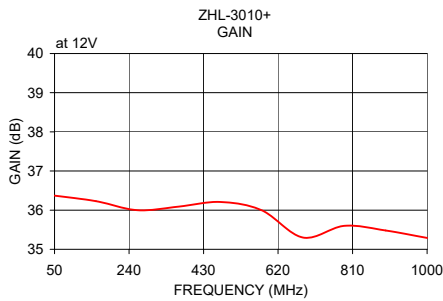

NOTES

- A. Performance and quality attributes and conditions not expressly stated in this specification document are intended to be excluded and do not form a part of this specification document.
- B. Electrical specifications and performance data contained in this specification document are based on Mini-Circuit's applicable established test performance criteria and measurement instructions.
- C. The parts covered by this specification document are subject to Mini-Circuits standard limited warranty and terms and conditions (collectively, "Standard Terms"); Purchasers of this part are entitled to the rights and benefits contained therein. For a full statement of the standard terms and the exclusive rights and remedies thereunder, please visit Mini-Circuits' website at www.minicircuits.com/terms/viewterm.html

